

Cilindri Serie 42

Semplice e doppio effetto, magnetici, ammortizzati
 ø 32, 40, 50, 63 mm

- » Perfetta linearità
- » Versatilità nei fissaggi

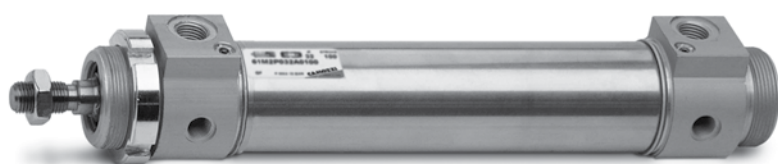

I cilindri della Serie 42 sono stati realizzati senza tiranti in modo da rendere più pulito il loro design. Tubo e stelo sono realizzati in acciaio INOX, mentre le testate sono in Alluminio anodizzato.

Questa serie di cilindri è normalmente fornita con ammortizzatori di fine corsa regolabili per mezzo di una vite posta sulla testata.

Per rendere meno rumoroso l'impatto del pistone sulla testata sono inoltre dotati di un ammortizzatore meccanico.

CARATTERISTICHE GENERALI

Costruzione	bordato
Funzione	a semplice e doppio effetto
Materiali	testate = AL - camicia = Inox AISI 304 - stelo = Inox AISI 420B altri: vedi codifica
Tipo di fissaggio	a flangia anteriore - a flangia posteriore - piedini cerniera anteriore e posteriore - perni filettati - ghiera
Corse min - max	10 - 1000 mm
Temperatura d'esercizio	0°C + 80°C (con aria secca -20°C)
Pressione d'esercizio	1 + 10 bar (doppio effetto); 2 + 10 bar (semplice effetto)
Velocità	10 + 1000 mm/sec (senza carico)
Fluido	aria filtrata, senza lubrificazione. Nel caso si utilizzasse aria lubrificata, si consiglia olio ISOVG32 e di non interrompere mai la lubrificazione.

TABELLA CORSE STANDARD CILINDRI SERIE 42

✕= Doppio effetto
 ■= Semplice effetto

CORSE STANDARD

Ø	25	50	75	80	100	125	150	160	200	250	300	320	400	500
32	✕ ■	✕ ■	✕ ■	✕	✕	✕	✕	✕	✕	✕	✕	✕	✕	✕
40	✕ ■	✕ ■	✕ ■	✕	✕	✕	✕	✕	✕	✕	✕	✕	✕	✕
50	✕ ■	✕ ■	✕ ■	✕	✕	✕	✕	✕	✕	✕	✕	✕	✕	✕
63	✕ ■	✕ ■	✕ ■	✕	✕	✕	✕	✕	✕	✕	✕	✕	✕	✕

ESEMPIO DI CODIFICA

42	M	2	N	050	A	0200
-----------	----------	----------	----------	------------	----------	-------------

42	SERIE
M	VERSIONE M = standard magnetico
2	FUNZIONAMENTO 1 = semplice effetto (molla anteriore) 2 = doppio effetto ammortizzato anteriore + posteriore 3 = doppio effetto 4 = doppio effetto ammortizzato posteriore 5 = doppio effetto ammortizzato anteriore 6 = doppio effetto stelo passante ammortizzato posteriore anteriore 7 = semplice effetto stelo passante non ammortizzato SIMBOLI PNEUMATICI CS07 CD09 CD08 CD10 CD11 CD13 CS11
N	CARATTERISTICHE MATERIALI N = stelo Inox AISI 420B - camicia Inox AISI 304 - guarnizioni NBR
050	ALESAGGIO 032 = 32 mm - 040 = 40 mm - 050 = 50 mm - 063 = 63 mm
A	TIPO COSTRUTTIVO A = standard (ghiera V + dado stelo U)
0200	CORSA (vedi tabella)

SIMBOLI PNEUMATICI

I simboli pneumatici indicati nell'ESEMPIO DI CODIFICA sono riportati di seguito.

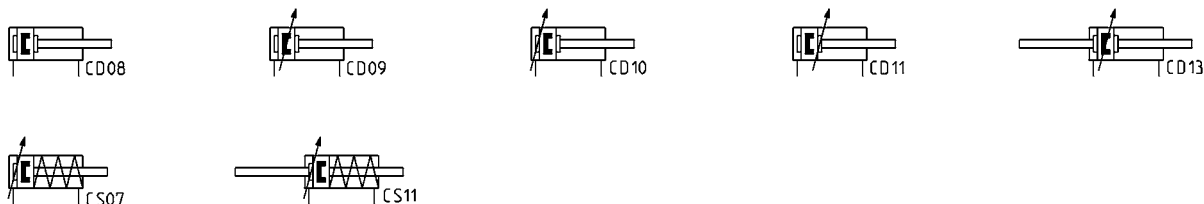

ACCESSORI CILINDRI SERIE 42
1

MOVIMENTO



Ghiera Mod. V-42

 Giunto compensatore
Mod. GKF

 Snodo autoallineante
Mod. GK

 Snodo sferico maschio
Mod. GY

Forcella per stelo Mod. G

 Ancoraggio piedini /
flangia Mod. P

 Ancoraggio a cerniera
Mod. I

Snodo sferico Mod. GA

 Ancoraggio a perno
Mod. T

Dado stelo Mod. U



Tutti gli accessori sono forniti separatamente al cilindro, fatta eccezione per il dado stelo Mod. U e per la ghiera Mod. V.

Cilindri Serie 42

N.B.: Le quote L, L1 e L2 nella versione semplice effetto aumentano di 25 mm.



+ = sommare la corsa

* = corsa ammortizzo anteriore/posteriore

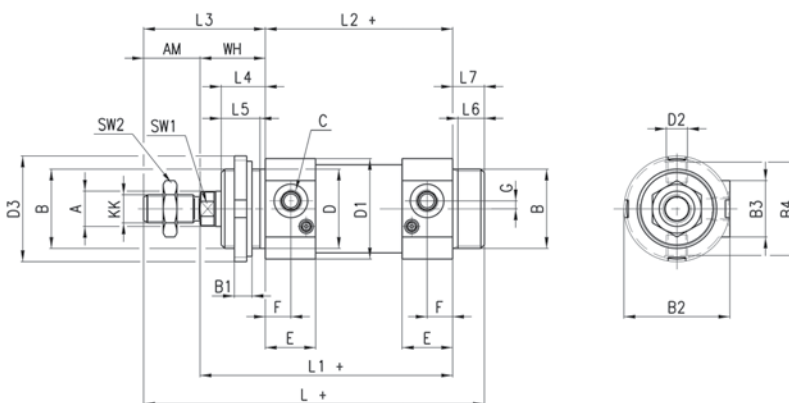

INGOMBRI

Ø	A	KK	B	B1	B2	B3	B4	C	D ²¹¹	D1	D2	D3	E	F	G	SW1	SW2	AM	WH	L+	L1+	L2+	L3	L4	L5	L6	L7	*
32	12	M10x1.25	M30x1.5	8	41.5	28	36	G1/8	30	38	M8x1	42	23.5	10.5	5	10	17	22	26	156	120	94	48	18	15	11	14	17 / 12
40	16	M12x1.25	M38x1.5	10	50	30	43	G1/4	38	46	M10x1	50	29	15	5	13	19	24	30	175	135	105	54	22	19	13	16	20 / 17
50	20	M16x1.5	M45x1.5	10	58.5	32	54	G1/4	40	57	M12x1.5	60	28.5	14.5	4.5	17	24	32	37	193	143	106	69	25	22	15	18	15 / 14
63	20	M16x1.5	M45x1.5	10	70.5	46.5	66	G3/8	45	70	M14x1.5	60	35	15	7	17	24	32	37	208	158	121	69	25	22	15	18	17 / 16

Cilindri Serie 42 - stelo passante

N.B.: Le quote L, L1 e L2 nella versione semplice effetto aumentano di 25 mm.



+ = sommare la corsa
++ = sommare la corsa 2 volte

* = corsa ammortizzo anteriore/posteriore

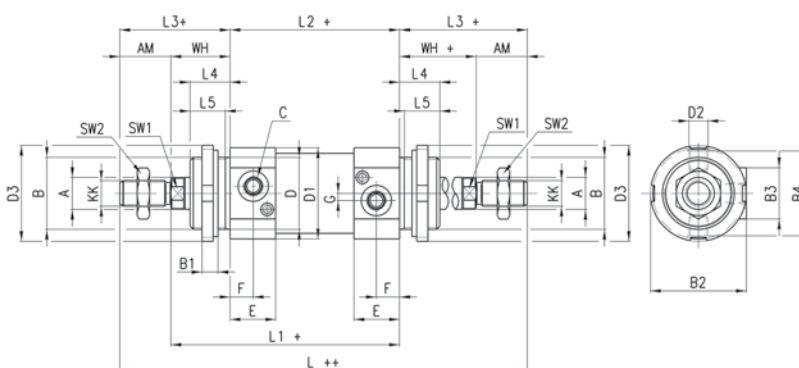

INGOMBRI

Ø	A	KK	B	B1	B2	B3	B4	C	D	D1	D2	D3	E	F	G	SW1	AM	SW2	WH+	L++	L1+	L2+	L3+	L4	L5	*
32	12	M10x1.25	M30x1.5	8	41.5	28	36	G1/8	30	38	M8x1	42	23.5	10.5	5	10	22	17	26	190	120	94	48	18	15	17 / 12
40	16	M12x1.25	M38x1.5	10	50	30	43	G1/4	38	46	M10x1	50	29	15	5	13	24	19	30	213	135	105	54	22	19	20 / 17
50	20	M16x1.5	M45x1.5	10	58.5	32	54	G1/4	45	57	M12x1.5	60	28.5	14.5	4.5	17	32	24	37	244	143	106	69	25	22	15 / 14
63	20	M16x1.5	M45x1.5	10	70.5	46.5	66	G3/8	45	70	M14x1.5	60	35	15	7	17	32	24	37	259	158	121	69	25	22	17 / 16

Ancoraggio piedini / flangia Mod. P

Materiale: Acciaio zincato

 La fornitura comprende:
 N° 1 ghiera
 N° 2 piedini

+ = sommare la corsa

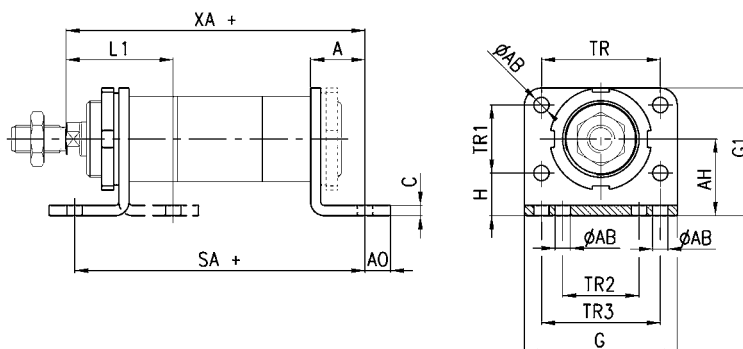
INGOMBRI

Mod.	Ø	L1	SA +	XA +	A	AB	AO	AH	C	G	G1	TR	TR1	TR2	TR3	H
P-42-32	32	46	142	144	24	7	11	32	4	66	53	52	28	32	52	18
P-42-40	40	53	161	163	28	9	15	36	5	80	61	60	30	36	60	21
P-42-50	50	63	170	175	32	9	15	45	6	90	75	70	40	45	70	25
P-42-63	63	63	185	190	32	9	10	50	6	96	85	76	50	50	76	25

Ancoraggio a cerniera Mod. I

Materiale: Acciaio zincato

 La fornitura comprende:
 N° 2 boccole
 N° 1 cerniera femmina
 N° 2 perni

+ = sommare la corsa

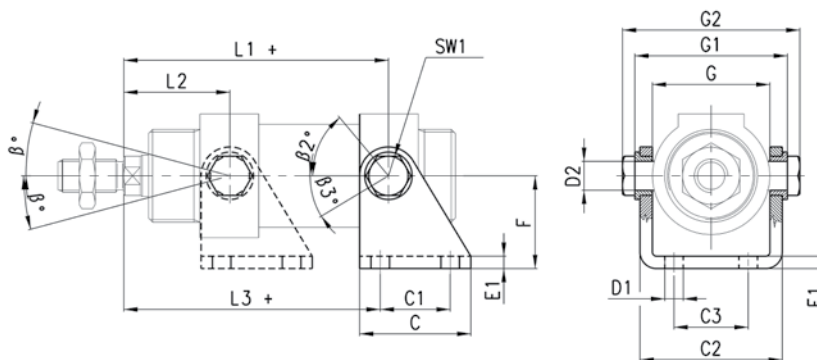

INGOMBRI

Mod.	Ø	L1 +	L2	L3 +	C	C1	C2	C3	D1	D2	E1	F	SW1	G	G1	G2
I-42-32	32	109,5	36,5	105,5	40	24	46,1	20	7	10	4	35	13	38,1	50,1	58,1
I-42-40	40	120	45	117	50	30	56,1	28	9	12	5	40	17	46,1	60,1	70,1
I-42-50	50	128,5	51,5	124,5	54	34	69,1	36	9	14	6	45	19	57,1	74,1	86,1
I-42-63	63	143	52	142	65	35	82,1	42	9	16	6	50	19	70,1	88,1	100,1

Ancoraggio a perno Mod. T

Materiale: Acciaio Inox

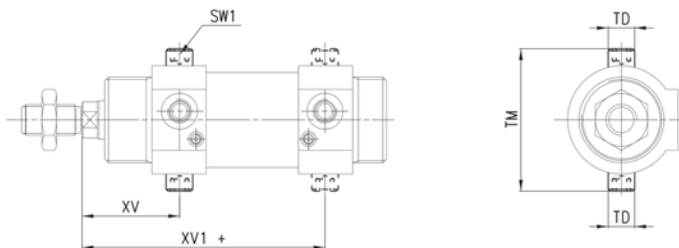
La fornitura comprende:
N° 2 perni



+ = sommare la corsa

INGOMBRI						
Mod.	Ø	XV	XV1+	TD	TM	SW1
T-42-32	32	36,5	109,5	10	51	5
T-42-40	40	45	120	12	61	6
T-42-50	50	51,5	128,5	14	75	6
T-42-63	63	52	143	16	90	8

Ghiera Mod. V-42

Materiale: Acciaio zincato

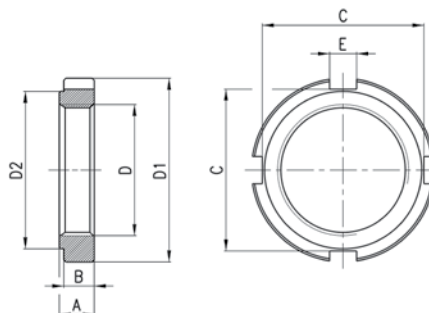

INGOMBRI								
Mod.	Ø	D	D1	D2	A	B	C	E
V-42-32	32	M30X1,5	42	36	8	7	37	6,2
V-42-40	40	M38x1,5	50	48	10	9	44	7,2
V-42-50-63	50-63	M45x1,5	60	56	10	9	53	7,2

Forcella Mod. G

ISO 8140

Materiale: Acciaio zincato

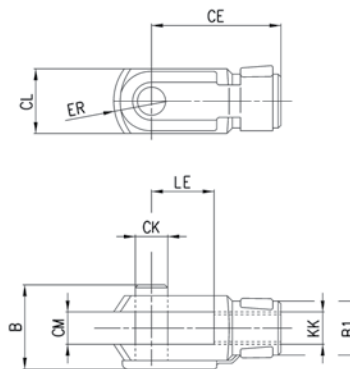

INGOMBRI										
Mod.	Ø	Ø CK	LE	CM	CL	ER	CE	KK	B	B1
G-25-32	32	10	20	10	20	12	40	M10X1,25	26	18
G-40	40	12	24	12	24	14	48	M12X1,25	32	20
G-50-63	50-63	16	32	16	32	19	64	M16X1,5	40	26

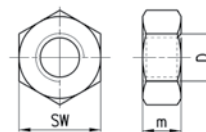
Dado stelo Mod. U

INGOMBRI				
Mod.	∅	D	m	SW
U-25-32	32	M10X1,25	6	17
U-40	40	M12X1,25	7	19
U-50-63	50-63	M16X1,5	8	24

Snodo sferico Mod. GA

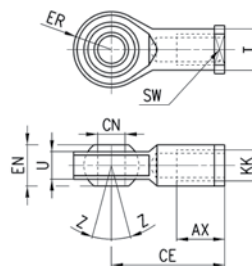
 ISO 8139
 Materiale: Acciaio zincato

INGOMBRI											
Mod.	∅	∅CN	U	EN	ER	AX	CE	KK	T	Z	SW
GA-32	32	10	10,5	14	14	20	43	M10X1,25	15	6,5	17
GA-40	40	12	12	16	16	22	50	M12X1,25	17,5	6,5	19
GA-50-63	50-63	16	15	21	21	28	64	M16X1,5	22	7,5	22

Snodo sferico maschio Mod. GY

Materiale: Zama e Acciaio zincato

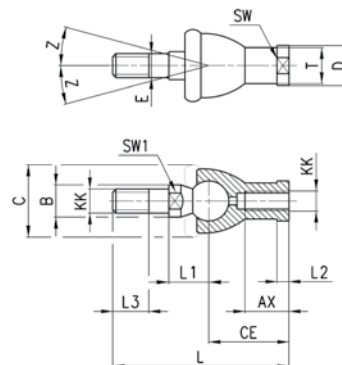

INGOMBRI																
Mod.	∅	KK	L	CE	L2	AX	SW	SW1	L1	L3	∅T	∅D	E	∅B	∅C	Z
GY-32	32	M10x1,25	74	35	6,5	18	17	11	19,5	15	15	19	10	14	28	15
GY-40	40	M12x1,25	84	40	6,5	20	19	17	22	17	17,5	22	12	19	32	15
GY-50-63	50-63	M16x1,5	112	50	8	27	22	19	27,5	23	22	27	16	22	40	11

Snodo autoallineante Mod. GK

Materiale: Acciaio zincato

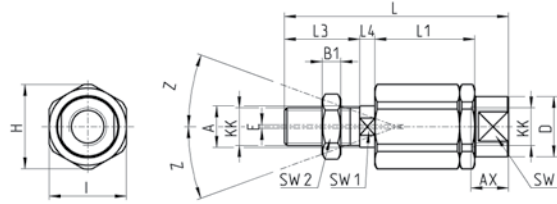

INGOMBRI

Mod.	Ø	KK	L	L1	L3	L4	Ø A	Ø D	H	I	SW	SW1	SW2	B1	AX	Z	E
GK-25-32	32	M10x1,25	71,5	35	20	7,5	14	22	32	30	19	12	17	5	22	4	2
GK-40	40	M12x1,25	75,5	35	24	7,5	14	22	32	30	19	12	19	6	22	4	2
GK-50-63	50-63	M16x1,5	104	53	32	10	22	32	45	41	27	20	24	8	30	3	2

Giunto compensatore Mod. GKF

Materiale: Acciaio zincato

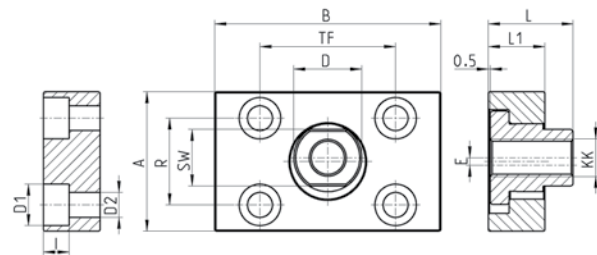
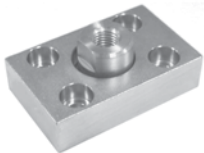

INGOMBRI

Mod.	Ø	KK	A	B	R	TF	L	L1	I	ØD	ØD1	ØD2	SW	E
GKF-25-32	32	M10x1,25	37	60	23	36	22,5	15	6,8	18	11	6,6	15	2
GKF-40	40	M12x1,25	56	60	38	42	22,5	15	9	20	15	9	15	2,5
GKF-50-63	50-63	M16x1,5	80	80	58	58	26,5	15	10,5	25	18	11	22	2,5