

Cilindri a tubo e profilo in alluminio Serie 63

Novità

Semplice e doppio effetto, magnetici, ammortizzati
Versioni standard, basso attrito, alte e basse temperature
Ø 32, 40, 50, 63, 80, 100, 125 mm



I nuovi attuatori pneumatici Serie 63, conformi alla norma ISO 15552, sono stati sviluppati per garantire elevate prestazioni con un peso contenuto. Grazie al nuovo sistema di ammortizzatori pneumatici regolabili e meccanici, i cilindri Serie 63 sono in grado di ridurre la rumorosità dovuta all'impatto di finecorsa.

Su un lato del profilo sono ricavate le cave per applicare e posizionare i sensori a scomparsa (Serie CSH) per il rilevamento della posizione del pistone. Queste cave possono essere coperte con un profilo copricava Mod. S-CST-500. L'ampia gamma di versioni disponibili consente l'utilizzo di questa serie in molteplici settori e applicazioni.

- » Conformi alla normativa ISO 15552 e alle precedenti norme DIN/ISO 6431 - VDMA 24562
- » Disegno pulito
- » Peso ridotto del 25%
- » Ammortizzatori di finecorsa pneumatici regolabili e meccanici
- » Ampia gamma di accessori per l'installazione
- » Stelo in acciaio INOX rullato

AMPIA GAMMA DI VERSIONI DISPONIBILI:

- » Basso attrito
- » Alte e basse temperature
- » Ambienti polverosi
- » ATEX

CARATTERISTICHE GENERALI

Costruzione	a profilo (con viti) e a tubo tondo (con tiranti)
Funzionamento	semplice effetto e doppio effetto
Materiali	vedere tabella pagina seguente
Fissaggio	a flangia anteriore / posteriore, con piedini, con cerniera anteriore / posteriore / snodata / intermedia
Corse min - max	10 ÷ 2500 mm
Temperatura d'esercizio	standard e basso attrito: 0°C ÷ 80°C (con aria secca -20°C); alte temperature (versione W): 0°C ÷ 150°C (con aria secca -20°C); basse temperature (versione Z): -40°C ÷ 60°C (con aria secca -40°C); basse temperature (versione Y): -50°C ÷ 60°C (con aria secca -50°C);
Pressione d'esercizio	1 ÷ 10 bar (standard, alte e basse temperature); 0,1 ÷ 10 bar (basso attrito)
Velocità	10 ÷ 1000 mm/sec, senza carico (standard, alte e basse temperature); 5 ÷ 1000 mm/sec, senza carico (basso attrito)
Fluido	aria filtrata in classe 7.8.4 secondo ISO 8573-1. Nel caso si utilizzasse aria lubrificata, si consiglia olio ISOVG32 e di non interrompere mai la lubrificazione.

TABELLA CORSE STANDARD CILINDRI SERIE 63

■ = Semplice effetto (standard, alte e basse temperature) ✕ = Doppio effetto (standard, basso attrito, alte e basse temperature)
 A richiesta sono disponibili corse diverse dalle corse riportate in tabella, fino ad un max di 2500 mm

CORSE STANDARD														
Ø	25	50	75	80	100	125	150	160	200	250	300	320	400	500
32	■ ✕	■ ✕	■ ✕	✕	✕	✕	✕	✕	✕	✕	✕	✕	✕	✕
40	■ ✕	■ ✕	■ ✕	✕	✕	✕	✕	✕	✕	✕	✕	✕	✕	✕
50	■ ✕	■ ✕	■ ✕	✕	✕	✕	✕	✕	✕	✕	✕	✕	✕	✕
63	■ ✕	■ ✕	■ ✕	✕	✕	✕	✕	✕	✕	✕	✕	✕	✕	✕
80	■ ✕	■ ✕	■ ✕	✕	✕	✕	✕	✕	✕	✕	✕	✕	✕	✕
100		■ ✕	■ ✕	✕	✕	✕	✕	✕	✕	✕	✕	✕	✕	✕
125		■ ✕	■ ✕	✕	✕	✕	✕	✕	✕	✕	✕	✕	✕	✕

ESEMPIO DI CODIFICA

63	M	P	2	C	050	A	0200			
----	---	---	---	---	-----	---	------	--	--	--

63	SERIE
M	VERSIONE: M = standard, magnetico L = basso attrito, magnetico
P	COSTRUZIONE: T = tubo tondo P = profilo
2	FUNZIONAMENTO: 1 = semplice effetto, molla anteriore 2 = doppio effetto 6 = doppio effetto, stelo passante 7 = semplice effetto, stelo passante 9 = semplice effetto, molla posteriore
C	AMMORTIZZO: N = senza ammortizzo C = ammortizzo su entrambi i lati F = ammortizzo anteriore R = ammortizzo posteriore
050	ALESAGGIO: 032 = 32 mm 040 = 40 mm 050 = 50 mm 063 = 63 mm 080 = 80 mm 100 = 100 mm 125 = 125 mm
A	TIPO COSTRUTTIVO: A = standard con dado stelo RL = cilindro con bloccastelo F = cilindro con cerniera intermedia (solo per costruzione a tubo tondo)
0200	CORSE: 10 ÷ 2500 mm
	RANGE DI TEMPERATURA: = standard W = alte temperature (150°C) Z = basse temperature (-40°C) Y = basse temperature (-50°C) - escluso Ø125
	RESISTENZA ALLA CORROSIONE: = standard (vedi tabella caratteristiche generali pag. 1/1.28.01) C1 = dado stelo INOX AISI 304, stelo INOX AISI 304 (altri materiali: vedi tabella caratteristiche generali pag. 1/1.28.01)
	VARIANTI STELO: = standard (_ _) = stelo più lungo di _ _ mm L = senza guarnizione stelo (solo alimentazione posteriore)* R = guarnizione stelo in NBR V = guarnizione stelo in FKM G = ambienti secchi e polverosi (con raschiastelo in ottone e stelo in acciaio inox 420B cromato)
	* La possibilità di eliminare la guarnizione dello stelo riduce ulteriormente la resistenza allo scorrimento per applicazioni in spinta.
	Aggiungere EX per ordinare la versione certificata ATEX.

SIMBOLI PNEUMATICI

I simboli pneumatici indicati nell'ESEMPIO DI CODIFICA sono riportati di seguito.

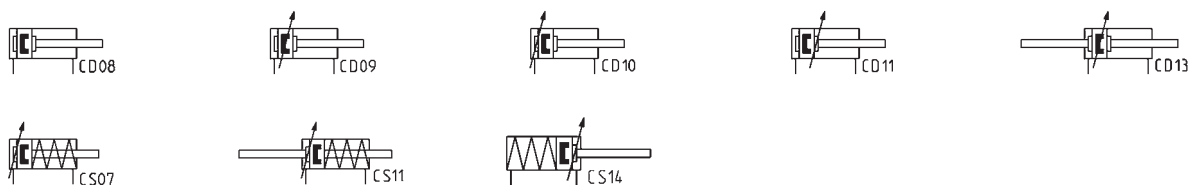
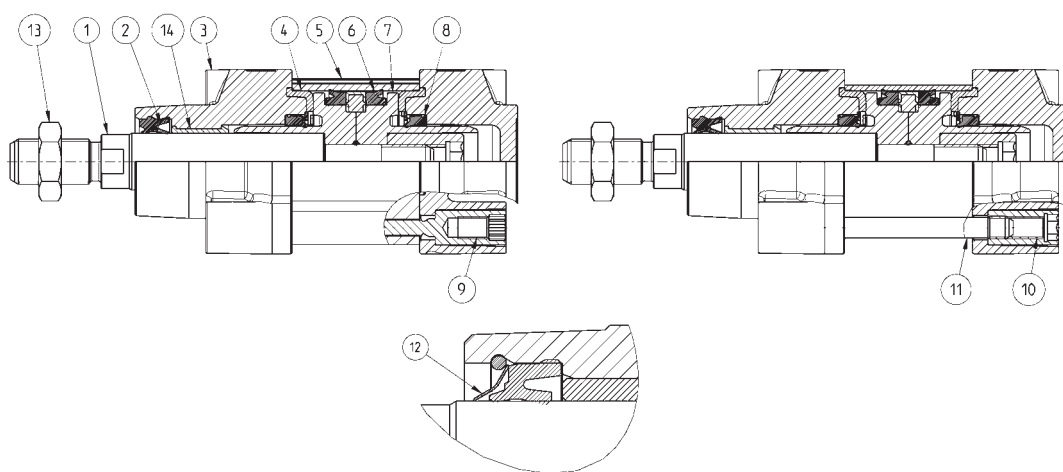

MATERIALI

ELENCO COMPONENTI

	Standard a profilo	Standard a tubo tondo	Basso attrito (L)	Raschiastelo (G)	Basse temperature (Z/Y)	Alte temperature (W)	Resistenza a corrosione (C1)
PARTI							
1 - Stelo	AISI 420B	AISI 420B	AISI 420B	AISI 420B cromato	AISI 420B cromato	AISI 420B	AISI 304
2 - Guarnizione stelo	PU	PU	NBR	NBR	PU per -40°C/-50°C	FKM	PU
3 - Testata	Alluminio	Alluminio	Alluminio	Alluminio	Alluminio	Alluminio	Alluminio
4 - Guarnizione di battuta	NBR	NBR	NBR	NBR	PU per -40°C/-50°C	FKM	NBR
5 - Profilo estruso	Alluminio anodizzato	Alluminio anodizzato	Alluminio anodizzato	Alluminio anodizzato	Alluminio anodizzato	Alluminio anodizzato	Alluminio anodizzato
6 - Guarnizione pistone	PU	PU	NBR	PU	PU per -40°C/-50°C	FKM	PU
7 - Pistone	Tecnopolimero (ø 32) o alluminio (ø 40 ÷ 125)	Alluminio (ø 125) o tecnopolimero (ø 32 ÷ 100)	Alluminio	Alluminio	Alluminio	Alluminio	Alluminio
8 - Guarnizione di ammortizzo	PU	PU	PU	PU	PU	FKM	PU
9 - Vite autofornante	Acciaio zincato	-	Acciaio zincato	Acciaio zincato	Acciaio zincato	Acciaio zincato	Acciaio zincato
10 - Dado tirante	-	Acciaio zincato	Acciaio zincato	Acciaio zincato	AISI 303	Acciaio zincato	Acciaio zincato
11 - Tirante	-	Acciaio zincato	Acciaio zincato	Acciaio zincato	AISI 420B	Acciaio zincato	Acciaio zincato
12 - Raschiastelo	-	-	-	Ottone	Ottone	-	-
13 - Dado stelo	Acciaio zincato	Acciaio zincato	Acciaio zincato	Acciaio zincato	AISI 304	Acciaio zincato	AISI 304
14 - Boccola guida stelo	Tecnopolimero	Tecnopolimero	Tecnopolimero	Tecnopolimero	Tecnopolimero	Acciaio + PTFE	Tecnopolimero

Cilindri Serie 63 basso attrito - ESEMPI DI APPLICAZIONE

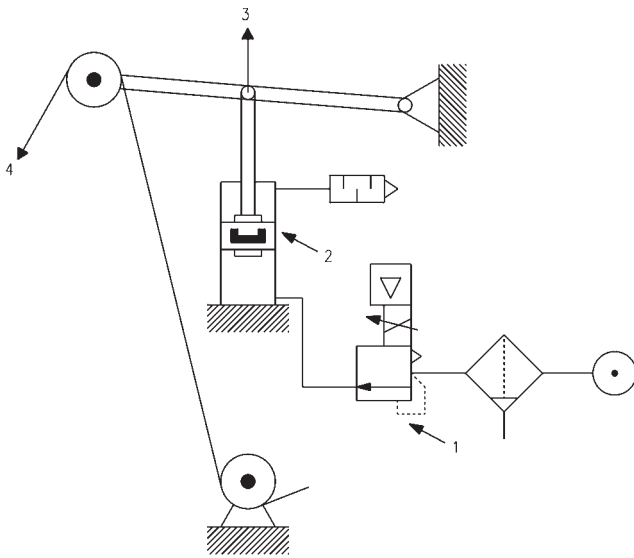
1

MOVIMENTO



CILINDRO IN SPINTA

NOTE AL DISEGNO:

1. Regolatore di pressione di precisione o regolatore proporzionale
2. Cilindro basso attrito
3. Direzione forza
4. Nastro

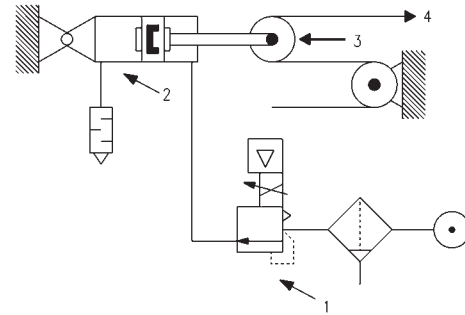

CILINDRO IN TRAZIONE

N.B. Per ottenere il massimo delle prestazioni, si consiglia di abbinare al cilindro a basso attrito un regolatore di pressione di precisione oppure un regolatore proporzionale come indicato nel disegno.

ACCESSORI DISPONIBILI PER LA SERIE 63

Snodo sferico maschio Mod. GY



Dado stelo Mod. U



Spinotto Mod. S



Cerniera con snodo sferico Mod. R



Giunto compensatore Mod. GKF



Snodo sferico Mod. GA



Supp. 90° per cerniera femmina Mod. ZC



Combinazione di accessori Mod. C+L+S



Flangia anteriore e posteriore Mod. D-E



Snodo autoallineante Mod. GK



Ancoraggio a cerniera interm. Mod. F-63, profilo



Ancoraggio a piedini Mod. B-41



Cerniera femmina anteriore Mod. H e C-H



Cerniera femmina posteriore Mod. C e C-H



Forcella Mod. G



Cerniera maschio posteriore Mod. L



Chiave smontaggio cil. Ø 80 e 100, tubo tondo



Supporto per cerniera intermedia Mod. BF



Ancoraggio a cerniera ant/post lamata Mod. FN



Accessorio per contrapposti Mod. DC-63



Ancoraggio a cerniera interm. Mod. F, tubo tondo



Tutti gli accessori sono forniti separatamente al cilindro, fatta eccezione del dado stelo Mod. U

Cilindri Serie 63 a profilo, semplice effetto, molla anteriore

Versioni: 63MP1... e 63LP1...

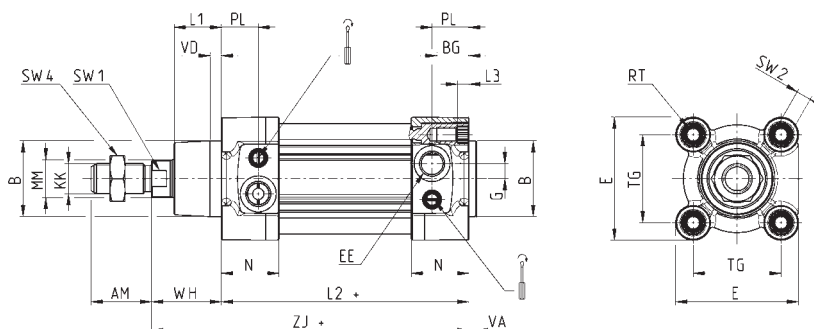

+ = sommare la corsa

INGOMBRI

Ø	ØMM	KK	ØB	PL	L1	AM	VA	EE	WH	L2	L3	ZJ	VD	N	BG	RT	G	TG	E	SW1	SW2	SW4
32	12	M10x1.25	30	18.5	18	22	4	G1/8	26	119	5.5	145	5	27	16	M6	5	32.5	47	10	6	17
40	16	M12x1.25	35	19	21	24	4	G1/4	30	130	5.5	160	5	30	16	M6	5	38	55	13	6	19
50	20	M16x1.5	40	19.5	25	32	4	G1/4	37	131	6	168	6	30.5	16	M8	8	46.5	65	17	8	24
63	20	M16x1.5	45	24	26	32	4	G3/8	37	146	6	183	6	37.5	16	M8	8	56.5	75	17	8	24
80	25	M20x1.5	45	23.5	30	40	4	G3/8	46	153	0	199	7	37	19	M10	8	72	93	22	6	30
100	25	M20x1.5	55	24	35	40	4	G1/2	51	163	0	214	7	39.5	19.5	M10	8	89	110	22	6	30
125	32	M27x2	60	28	42	54	6	G1/2	65	185	6	250	8	44	23	M12	10.5	110	135	27	12	41

Cilindri Serie 63 a profilo, semplice effetto, molla posteriore

Versioni: 63MP9... e 63LP9...

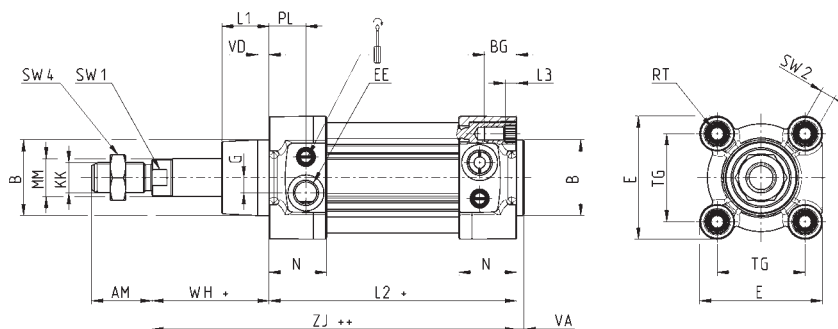
 + = sommare la corsa
 ++ = sommare la corsa due volte

INGOMBRI

Ø	ØMM	KK	ØB	PL	L1	AM	VA	EE	WH	L2	L3	ZJ	VD	N	BG	RT	G	TG	E	SW1	SW2	SW4
32	12	M10x1.25	30	18.5	18	22	4	G1/8	51	119	5.5	170	5	27	16	M6	5	32.5	47	10	6	17
40	16	M12x1.25	35	19	21	24	4	G1/4	55	130	5.5	185	5	30	16	M6	5	38	55	13	6	19
50	20	M16x1.5	40	19.5	25	32	4	G1/4	62	131	6	193	6	30.5	16	M8	8	46.5	65	17	8	24
63	20	M16x1.5	45	24	26	32	4	G3/8	62	146	6	208	6	37.5	16	M8	8	56.5	75	17	8	24
80	25	M20x1.5	45	23.5	30	40	4	G3/8	71	153	0	224	7	37	19	M10	8	72	93	22	6	30
100	25	M20x1.5	55	24	35	40	4	G1/2	76	163	0	239	7	39.5	19.5	M10	8	89	110	22	6	30
125	32	M27x2	60	28	42	54	6	G1/2	90	185	6	275	8	44	23	M12	10.5	110	135	27	12	41

Cilindri Serie 63 a tubo tondo, semplice effetto, molla anteriore

Versioni: 63MT1... e 63LT1...



+ = sommare la corsa

Nota tabella:
* = chiave speciale
80-62/8C
(vedi accessori)

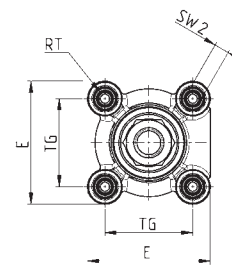
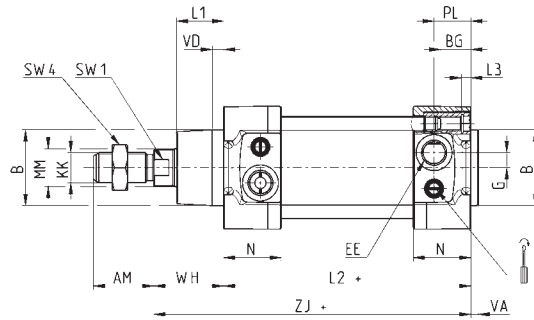

Ø32-40-50-63-125



Ø80-100

INGOMBRI																						
Ø	ØMM	KK	ØB	PL	L1	AM	VA	EE	WH	L2	L3	ZJ	VD	N	BG	RT	G	TG	E	SW1	SW2	SW4
32	12	M10x1.25	30	18.5	18	22	4	G1/8	26	119	5	145	5	27	16	M6	5	32.5	47	10	6	17
40	16	M12x1.25	35	19	21	24	4	G1/4	30	130	5	160	5	30	16	M6	5	38	55	13	6	19
50	20	M16x1.5	40	19.5	25	32	4	G1/4	37	131	5	168	6	30.5	16	M8	8	46.5	65	17	8	24
63	20	M16x1.5	45	24	26	32	4	G3/8	37	146	5	183	6	37.5	16	M8	8	56.5	75	17	8	24
80	25	M20x1.5	45	23.5	30	40	4	G3/8	46	153	0	199	7	37	19	M10	8	72	93	22	*	30
100	25	M20x1.5	55	24	35	40	4	G1/2	51	163	0	214	7	39.5	19.5	M10	8	89	110	22	*	30
125	32	M27x2	60	28	42	54	6	G1/2	65	185	6	250	8	44	23	M12	10.5	110	135	27	12	41

Cilindri Serie 63 a tubo tondo, semplice effetto, molla posteriore

Versioni: 63MT9... e 63LT9...



+ = sommare la corsa

Nota tabella:
* = chiave speciale
80-62/8C
(vedi accessori)

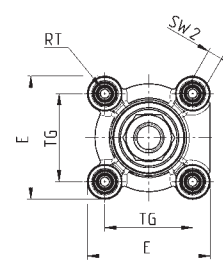
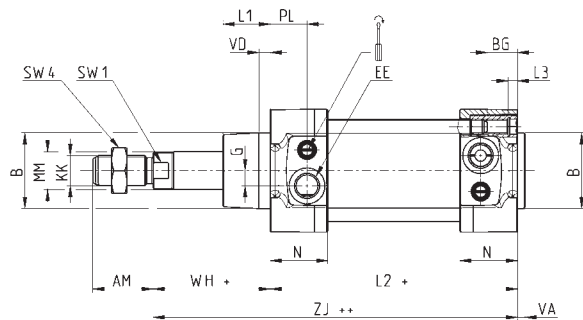

Ø32-40-50-63-125



Ø80-100

INGOMBRI																						
Ø	ØMM	KK	ØB	PL	L1	AM	VA	EE	WH	L2	L3	ZJ	VD	N	BG	RT	G	TG	E	SW1	SW2	SW4
32	12	M10x1.25	30	18.5	18	22	4	G1/8	51	119	5	170	5	27	16	M6	5	32.5	47	10	6	17
40	16	M12x1.25	35	19	21	24	4	G1/4	55	130	5	185	5	30	16	M6	5	38	55	13	6	19
50	20	M16x1.5	40	19.5	25	32	4	G1/4	62	131	5	193	6	30.5	16	M8	8	46.5	65	17	8	24
63	20	M16x1.5	45	24	26	32	4	G3/8	62	146	5	208	6	37.5	16	M8	8	56.5	75	17	8	24
80	25	M20x1.5	45	23.5	30	40	4	G3/8	71	153	0	224	7	37	19	M10	8	72	93	22	*	30
100	25	M20x1.5	55	24	35	40	4	G1/2	76	163	0	239	7	39.5	19.5	M10	8	89	110	22	*	30
125	32	M27x2	60	28	42	54	6	G1/2	90	185	6	275	8	44	23	M12	10.5	110	135	27	12	41

Cilindri Serie 63 a profilo, stelo passante

Versioni: 63MP6..., 63MP7..., 63LP6... e 63LP7...

Per i cilindri semplice effetto le quote L2 e ZJ vanno aumentate di 25mm.

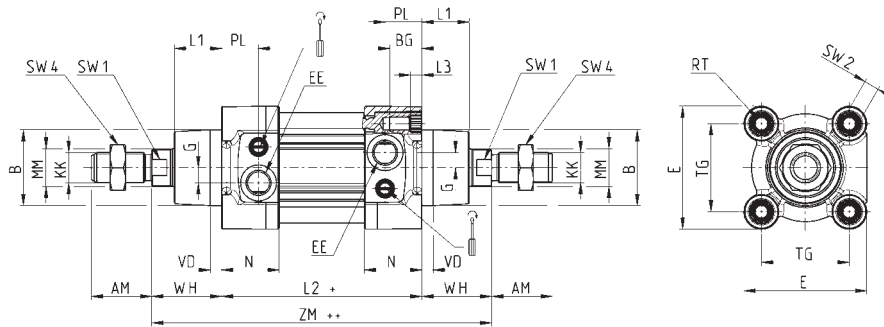

 + = sommare la corsa
 ++ = sommare la corsa due volte

INGOMBRI																						
Ø	ØMM	KK	ØB	PL	L1	AM	EE	WH	L2	L3	ZM	VD	N	BG	RT	G	TG	E	ØF	SW1	SW2	SW4
32	12	M10x1.25	30	18.5	18	22	G1/8	26	94	5.5	146	5	27	16	M6	5	32.5	47	-	10	6	17
40	16	M12x1.25	35	19	21	24	G1/4	30	105	5.5	165	5	30	16	M6	5	38	55	-	13	6	19
50	20	M16x1.5	40	19.5	25	32	G1/4	37	106	6	180	6	30.5	16	M8	8	46.5	65	8	17	8	24
63	20	M16x1.5	45	24	26	32	G3/8	37	121	6	195	6	37.5	16	M8	8	56.5	75	8	17	8	24
80	25	M20x1.5	45	23.5	30	40	G3/8	46	128	0	220	7	37	19	M10	8	72	93	8	22	6	30
100	25	M20x1.5	55	24	35	40	G1/2	51	138	0	240	7	39.5	19.5	M10	8	89	110	8	22	6	30
125	32	M27x2	60	28	42	54	G1/2	65	160	6	290	8	44	23	M12	10.5	110	135	-	27	12	41

Cilindri Serie 63 a tubo tondo stelo passante

Versioni: 63MT6..., 63MT7..., 63LT6... e 63LT7...

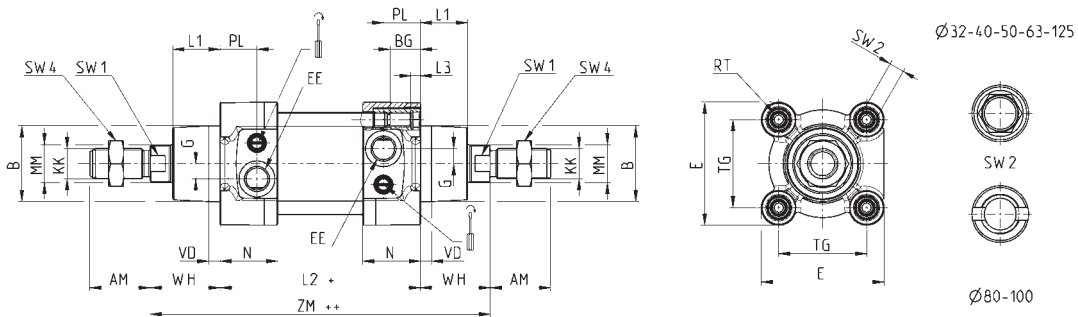
Per i cilindri semplice effetto le quote L2 e ZJ vanno aumentate di 25mm

 + = sommare la corsa
 ++ = sommare la corsa due volte

 Nota tabella:
 * = chiave speciale 80-62/8C (vedi accessori)

INGOMBRI																						
Ø	ØMM	KK	ØB	PL	L1	AM	EE	WH	L2	L3	ZM	VD	N	BG	RT	G	TG	E	ØF	SW1	SW2	SW4
32	12	M10x1.25	30	18.5	18	22	G1/8	26	94	5.5	146	5	27	16	M6	5	32.5	47	-	10	6	17
40	16	M12x1.25	35	19	21	24	G1/4	30	105	5.5	165	5	30	16	M6	5	38	55	-	13	6	19
50	20	M16x1.5	40	19.5	25	32	G1/4	37	106	6	180	6	30.5	16	M8	8	46.5	65	8	17	8	24
63	20	M16x1.5	45	24	26	32	G3/8	37	121	6	195	6	37.5	16	M8	8	56.5	75	8	17	8	24
80	25	M20x1.5	45	23.5	30	40	G3/8	46	128	0	220	7	37	19	M10	8	72	93	8	22	*	30
100	25	M20x1.5	55	24	35	40	G1/2	51	138	0	240	7	39.5	19.5	M10	8	89	110	8	22	*	30
125	32	M27x2	60	28	42	54	G1/2	65	160	6	290	8	44	23	M12	10.5	110	135	-	27	12	41

Cilindri Serie 63 con bloccastelo



+ = sommare la corsa

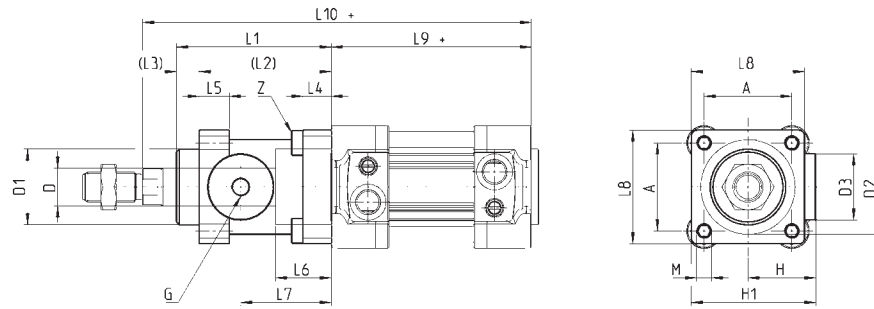

INGOMBRI																				
Ø	øD	øD1	øD2	øD3	A	G	H	H1	L1	L2	L3	L4	L5	L6	L7	L8	L9+	L10+	M	Z
32	12	30,5	35	25	32,5	M5	25,5	46,5	58	48	10	8	13	20,5	34	45	94	160	M6	M6x20
40	16	35	40	28	38	G1/8	30	53	65	55	10	8	13	22,5	38	50	105	178	M6	M6x20
50	20	40	50	35	46,5	G1/8	36	64	82	70	12	15	16	29,5	48	60	106	200	M8	M6x20
63	20	45	60	38	56,5	G1/8	40	75	82	70	12	15	16	29,5	49,5	70	121	215	M8	M8x30
80	25	45	80	48	72	G1/8	50	95	110	90	20	18	20	35	61	90	128	254	M10	M10x35
100	25	55	100	58	89	G1/8	58	110,5	115	100	15	18	20	39	69	105	138	269	M10	M10x35
125	32	60	130	65	110	G1/8	80	150	167	122	45	22	30	51	86,5	140	160	350	M12	M12x40

Accessorio per contrapposti Mod. DC-63

Materiale: Alluminio



La fornitura comprende:
 N° 1 flangia
 N° 8 grani
 N° 8 dadi

+ = sommare la corsa

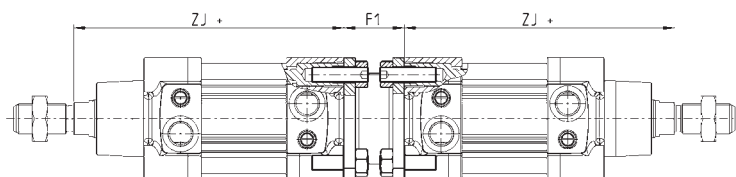

Mod.	Ø	F1	ZJ+	peso (g)	corsa max totale (mm)	coppia di serraggio
DC-63-32	32	27	120	130	500	5 Nm
DC-63-40	40	27	135	160	800	5 Nm
DC-63-50	50	32	143	285	800	10 Nm
DC-63-63	63	28	158	340	700	10 Nm
DC-63-80	80	38	174	670	1000	15 Nm
DC-63-100	100	38	189	820	900	15 Nm
DC-63-125	125	48	225	1300	1000	20 Nm

Ancoraggio a piedini Mod. B-41

Materiale: Acciaio zincato



La fornitura comprende:
 N° 2 piedini
 N° 4 viti

+ = sommare la corsa

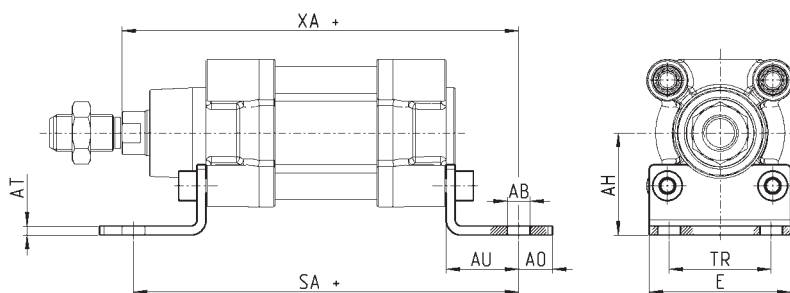

Mod.	Ø	AT	SA+	XA+	TR	E	AB	AH	AO	AU	coppia di serraggio
B-41-32	32	4	142	144	32	45	7	32	11	24	5 Nm
B-41-40	40	4	161	163	36	53,5	10	36	15	28	5 Nm
B-41-50	50	4	170	175	45	62,5	10	45	15	32	10 Nm
B-41-63	63	5	185	190	50	73	10	50	15	32	10 Nm
B-41-80	80	6	210	216	63	92	12	63	20	41	15 Nm
B-41-100	100	6	220	230	75	108,5	14,5	71	25	41	15 Nm
B-41-125	125	7	250	270	90	132	16,5	90	25	45	20 Nm

Ancoraggio a flangia anteriore e posteriore Mod. D-E

Materiale: Alluminio



La fornitura comprende:
N° 1 flangia
N° 4 viti

+ = sommare la corsa

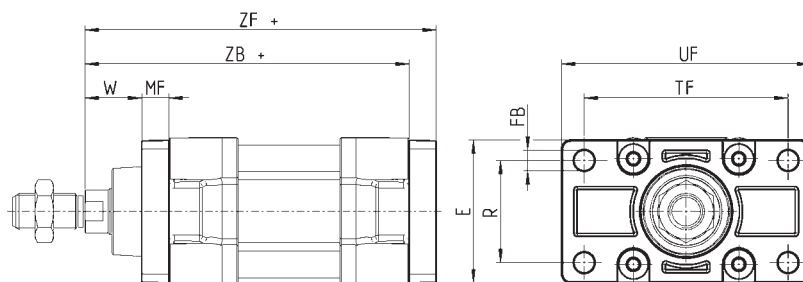

Mod.	Ø	W	MF	ZB+	TF	R	UF	E	FB	ZF+	Coppia di serraggio
D-E-41-32	32	16	10	120	64	32	86	45	7	130	5 Nm
D-E-41-40	40	20	10	135	72	36	88	52	9	145	5 Nm
D-E-41-50	50	25	12	143	90	45	110	63	9	155	10 Nm
D-E-41-63	63	25	12	158	100	50	116	73	9	170	10 Nm
D-E-41-80	80	30	16	174	126	63	148	95	12	190	15 Nm
D-E-41-100	100	35	16	189	150	75	176	115	14	205	15 Nm
D-E-41-125	125	45	20	225	180	90	224	135	16	245	20 Nm

Ancoraggio a cerniera femmina posteriore Mod. C e C-H

Materiale: Alluminio



La fornitura comprende:
N° 1 cerniera femmina
N° 4 viti

+ = sommare la corsa

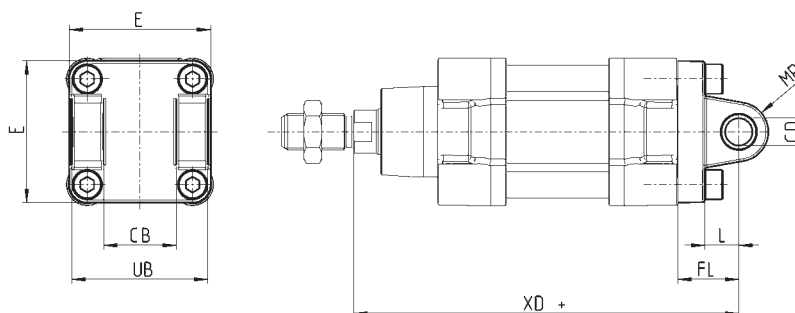

Mod.	Ø	CD	L	FL	XD+	MR	E	CB	UB	Coppia di serraggio
C-41-32	32	10	12	22	142	10	45	26	45	5 Nm
C-41-40	40	12	15	25	160	12	53.5	28	52	5 Nm
C-41-50	50	12	15	27	170	13	62.5	32	60	10 Nm
C-H-41-63	63	16	20	32	190	17	73	40	70	10 Nm
C-H-41-80	80	16	24	36	210	17	92	50	90	15 Nm
C-H-41-100	100	20	29	41	230	21	108.5	60	110	15 Nm
C-H-41-125	125	25	30	50	275	26	132	70	130	20 Nm

Ancoraggio a cerniera femmina anteriore Mod. H e C-H

Materiale: Alluminio

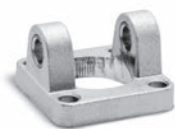
 La fornitura comprende:
 N° 1 cerniera femmina e
 N° 4 viti

+ = sommare la corsa

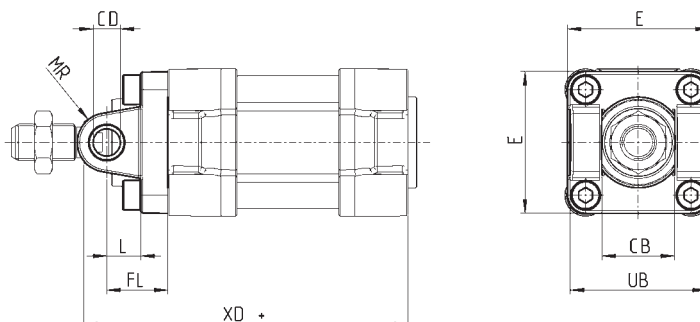

Mod.	Ø	CB	UB	E	XD	FL	L	CD	MR	coppia di serraggio
H-41-32	32	26	45	45	120	22	12	10	10	5 Nm
H-41-40	40	28	52	53.5	135	25	15	12	12	5 Nm
H-41-50	50	32	60	62.5	143	27	15	12	13	10 Nm
H-60-63	63	40	70	73	158	32	20	16	17	10 Nm
C-H-41-80	80	50	90	92	174	36	24	16	17	15 Nm
C-H-41-100	100	60	110	108.5	189	41	29	20	21	15 Nm
C-H-41-125	125	70	130	132	225	50	30	25	26	20 Nm

Ancoraggio a cerniera maschio posteriore Mod. L

Materiale: Alluminio

 La fornitura comprende:
 N° 1 cerniera maschio e
 N° 4 viti

+ = sommare la corsa

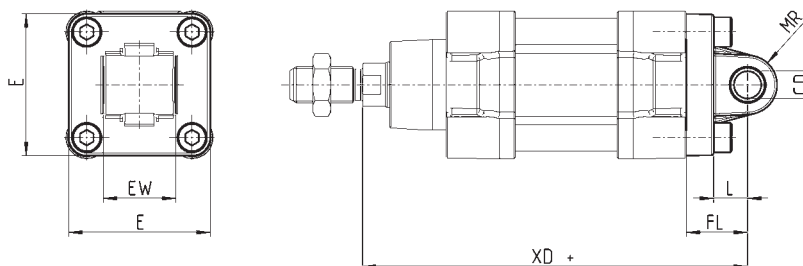

INGOMBRI										
Mod.	Ø	CD	L	FL	XD+	MR	E	EW	Coppia di serraggio	
L-41-32	32	10	12	22	142	10	45	26	5 Nm	
L-41-40	40	12	15	25	160	13	53.5	28	5 Nm	
L-41-50	50	12	15	27	170	13	62.5	32	10 Nm	
L-41-63	63	16	20	32	190	17	73	40	10 Nm	
L-41-80	80	16	24	36	210	17	92	50	15 Nm	
L-41-100	100	20	29	41	230	21	108.5	60	15 Nm	
L-41-125	125	25	30	50	275	26	132	70	20 Nm	

Ancoraggio a cerniera anteriore/posteriore lamata Mod. FN

Materiale: acciaio zincato



La fornitura comprende:
N° 1 cerniera intermedia lamata
N° 4 viti

+ = sommare la corsa

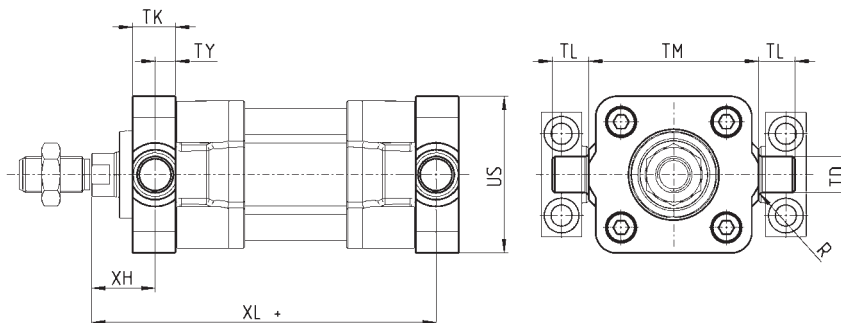

INGOMBRI											
Mod.	Ø	TK	TY	XH	XL	US	TL	TM	TD	R	coppia di serraggio
FN-32	32	14	6.5	19.5	126.5	46	12	50	12	1	5 Nm
FN-40	40	19	9	21	144	59	16	63	16	1.5	5 Nm
FN-50	50	19	9	28	152	69	16	75	16	1.6	10 Nm
FN-63	63	24	11.5	25.5	169.5	84	20	90	20	1.6	10 Nm
FN-80	80	24	11.5	34.5	185.5	102	20	110	20	1.6	15 Nm
FN-100	100	29	14	37	203	125	25	132	25	2	15 Nm
FN-125	125	30	15	50	240	150	25	160	25	2	20 Nm

Ancoraggio a cerniera intermedia Mod. F per cil. a tubo tondo

Materiale: acciaio zincato



La fornitura comprende:
N° 1 cerniera intermedia
N° 8 grani

+ = sommare la corsa

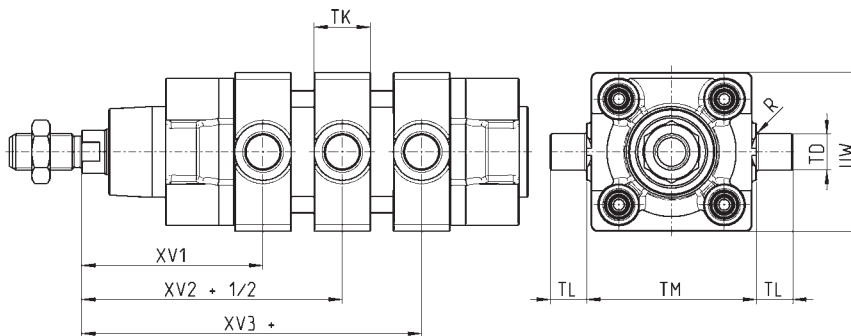

INGOMBRI										
Mod.	Ø	XV1	XV2	XV3	TM (h14)	TK	TD (e9)	TL	UW	R
F-32	32	62	73	84	50	20	12	12	50	0.5
F-40	40	69	82,5	96	63	20	16	16	60	1
F-50	50	79	90	101	75	25	16	16	70	1
F-63	63	86	97,5	109	90	25	20	20	85	1
F-80	80	97	110	123	110	30	20	20	105	1
F-100	100	104,5	120	135,5	132	30	25	25	125	1.5
F-125	125	123	145	167	160	30	25	25	155	1.5

Ancoraggio a cerniera intermedia Mod. F-63 per cil. a profilo

Materiale: acciaio zincato



La fornitura comprende:
 N° 1 cerniera intermedia
 N° 8 grani
 N° 2 viti di fissaggio

+ = sommare la corsa

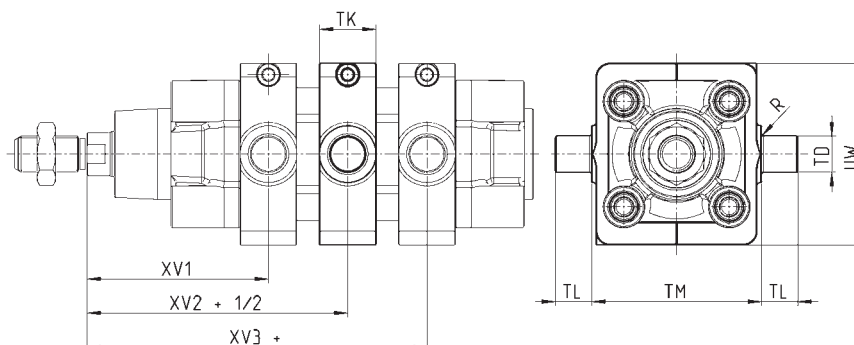
INGOMBRI

Mod.	Ø	XV1	XV2	XV3	TM	TK	TD	TL	UW	R
F-63-32	32	63	73	83	48	20	12	12	60	0.5
F-63-40	40	70	82.5	95	61	20	16	16	70	1
F-63-50	50	80	90	100	71	25	16	16	91	1
F-63-63	63	87	97.5	108	84	25	20	20	90	1
F-63-80	80	98	110	122	106	30	20	20	115	1
F-63-100	100	105.5	120	134.5	128	30	25	25	135	1.5
F-63-125	125	124	145	166	156	30	25	25	162	1.5

Combinazione di accessori Mod. C+L+S

Materiale: Alluminio

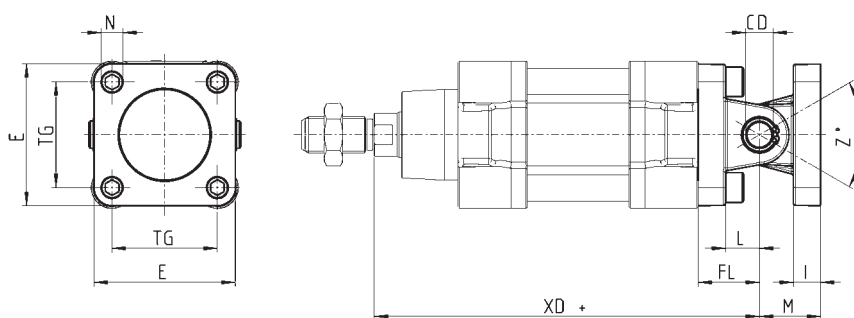

+ = sommare la corsa

INGOMBRI

Mod.	Ø	E	TG	°N	XD+	°CD	L	FL	I	M	Z° (max)	Coppia di serraggio
C+L+S	32	45	32.5	6.5	142	10	12	22	10	22	30	5 Nm
C+L+S	40	53.5	38	6.5	160	12	15	25	10	25	40	5 Nm
C+L+S	50	62.5	46.5	9	170	12	15	27	12	27	25	10 Nm
C+L+S	63	73	56.5	9	190	16	20	32	12	32	36	10 Nm
C+L+S	80	92	72	11	210	16	24	36	12	36	34	15 Nm
C+L+S	100	108.5	89	11	230	20	29	41	12	41	38	15 Nm
C+L+S	125	132	110	13	275	25	30	50	25	50	30	20 Nm

Supporto 90° per cerniera femmina Mod. ZC

CETOP RP 107P
Materiale: Alluminio



La fornitura comprende :
N°1 supporto maschio

+ = sommare la corsa

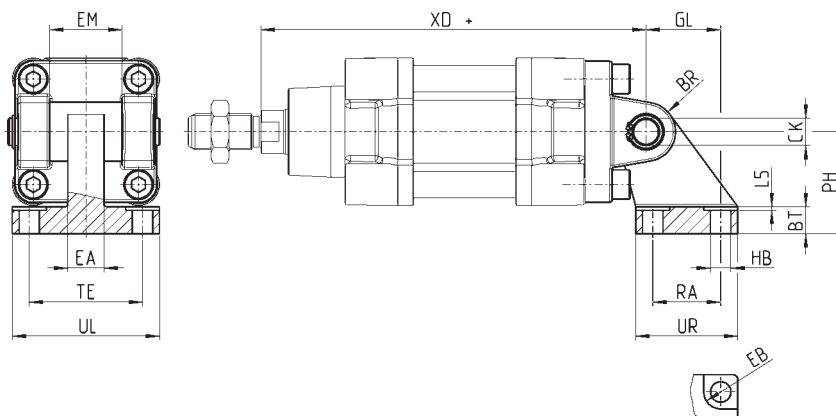

INGOMBRI																
Mod.	Ø	EB	CK	HB	XD+	TE	UL	EA	GL	L5	RA	EM	UR	PH	BT	BR
ZC-32	32	11	10	6,6	142	38	51	10	21	1,6	18	26	31	32	8	10
ZC-40	40	11	12	6,6	160	41	54	15	24	1,6	22	28	35	36	10	11
ZC-50	50	15	12	9	170	50	65	16	33	1,6	30	32	45	45	12	13
ZC-63	63	15	16	9	190	52	67	16	37	1,6	35	40	50	50	14	15
ZC-80	80	18	16	11	210	66	86	20	47	2,5	40	50	60	63	14	15
ZC-100	100	18	20	11	230	76	96	20	55	2,5	50	60	70	71	17	19
ZC-125	125	20	25	14	275	94	124	30	70	3,2	60	70	90	90	20	22,5

Ancoraggio a cerniera con snodo sferico Mod. R

Materiale: Alluminio
* quote non a norma ISO 15552

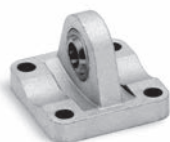

La fornitura comprende:
N° 1 cerniera snodata
N° 4 viti

+ = sommare la corsa

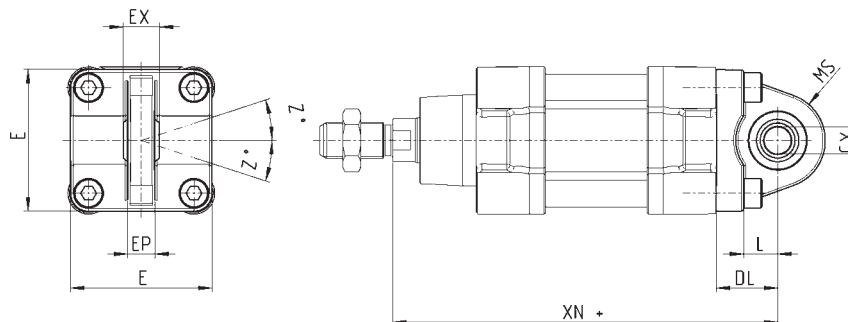

Mod.	Ø	CX	L	DL	XN+	MS	E	EX	EP	Z	Coppia di serraggio
R-41-32	32	10	12	22	142	18	45	14	10.5	4	5 Nm
R-41-40	40	12	15	25	160	18	53.5	16	12	4	5 Nm
R-41-50	50	12 *	15	27	170	21	62.5	16 *	12 *	4	10 Nm
R-41-63	63	16	20	32	190	23	73	21	15	4	10 Nm
R-41-80	80	16 *	24	36	210	28	92	21 *	15 *	4	15 Nm
R-41-100	100	20	29	41	230	30	108.5	25	18	4	15 Nm
R-41-125	125	30	30	50	275	40	140	37	25	4	20 Nm

Supporto per cerniera intermedia Mod. BF

Materiale: Alluminio

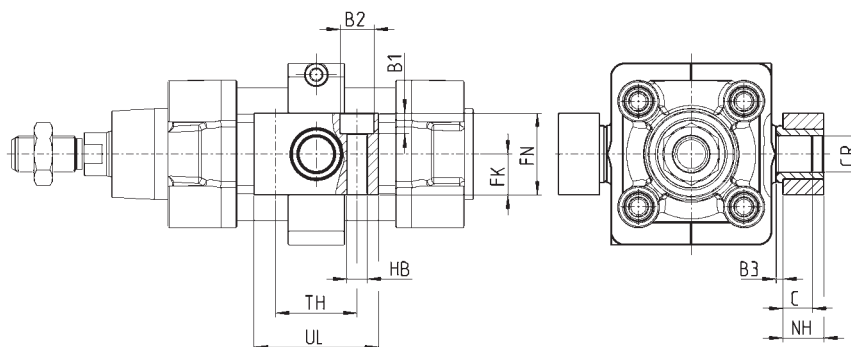
 La fornitura comprende:
N° 2 supporti

INGOMBRI

Mod.	Ø	CR	NH	C	B3	TH	UL	FK	FN	B1	B2	HB
BF-32	32	12	15	7,5	3	32	46	15	30	6,8	11	6,6
BF-40-50	40 - 50	16	18	9	3	36	55	18	36	9	15	9
BF-63-80	63 - 80	20	20	10	3	42	65	20	40	11	18	11
BF-100-125	100 - 125	25	25	12,5	3,5	50	75	25	50	13	20	14

Accessorio per il montaggio delle valvole sul cilindro

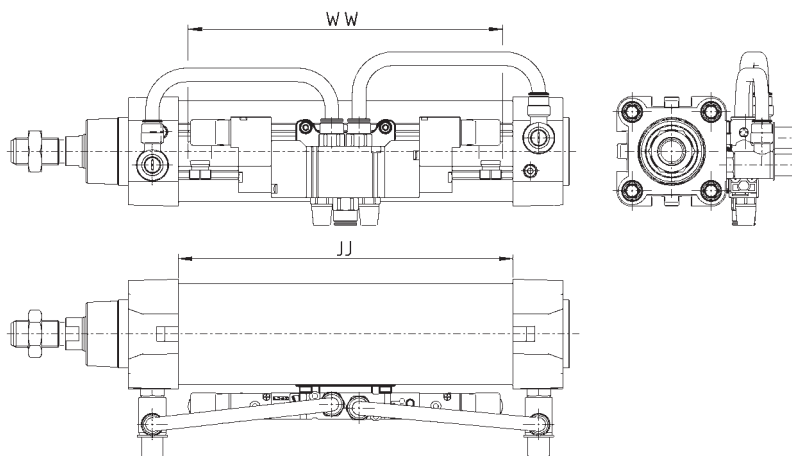
Le piastre di collegamento Mod. PCV permettono di collegare le valvole o le elettrovalvole direttamente sul cilindro, formando così una unità compatta da applicare.

 Verificare che la dimensione WW della valvola da fissare sia minore della dimensione JJ del cilindro scelto. Ulteriori informazioni su <http://catalogue.camozzi.com/downloads>.

Mod.

PCV-62-K3

per fissare valvole - elettrovalvole Serie 3

PCV-62-K4

per fissare valvole - elettrovalvole Serie 4 attacco G1/4

PCV-62-KEN

per fissare valvole - elettrovalvole Serie EN

PCV-62-K8

per fissare valvole - elettrovalvole Serie 4 attacco G1/8 e Serie 3 attacco G1/4

Spinotto Mod. S

La fornitura comprende:
 N° 1 spinotto in acciaio INOX 303
 N° 2 seeger in acciaio

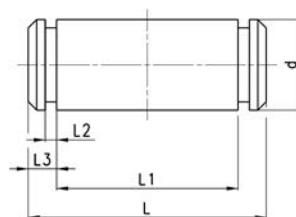

INGOMBRI						
Mod.	∅	d	L	L1	L2	L3
S-32	32	10	52	46	1.1	3
S-40	40	12	59	53	1.1	3
S-50	50	12	67	61	1.1	3
S-63	63	16	77	71	1.1	3
S-80	80	16	97	91	1.1	3
S-100	100	20	121	111	1.3	5
S-125	125	25	140.5	132	1.3	4.25

Snodo sferico Mod. GA

ISO 8139
 Materiale: Acciaio zincato

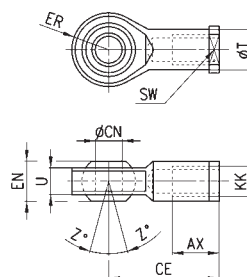

Mod.	∅CN	U	EN	ER	AX	CE	KK	T	Z	SW
GA-32	10	10,5	14	14	20	43	M10X1,25	15	6,5	17
GA-40	12	12	16	16	22	50	M12X1,25	17,5	6,5	19
GA-50-63	16	15	21	21	28	64	M16X1,5	22	7,5	22
GA-80-100	20	18	25	25	33	77	M20x1,5	27,5	7	30
GA-112-125	30	25	37	37	51	110	M27x2	40	7,5	41

Snodo sferico maschio Mod. GY

Materiale: Zama e Acciaio zincato

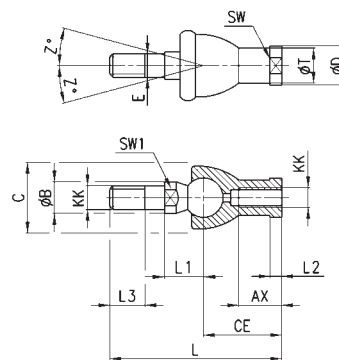

INGOMBRI																
Mod.	∅	KK	L	CE	L2	AX	SW	SW1	L1	L3	∅T	∅D	E	∅B	∅C	Z
GY-32	32	M10X1,25	74	35	6,5	18	17	11	19,5	15	15	19	10	14	28	15
GY-40	40	M12X1,25	84	40	6,5	20	19	17	21	17	17,5	22	12	19	32	15
GY-50-63	50-63	M16X1,5	112	50	8	27	22	19	27,5	23	22	27	16	22	40	11
GY-80-100	80-100	M20x1,5	133	63	10	38	30	24	31,5	25	27,5	34	20	27	45	7,5

Forcella Mod. G

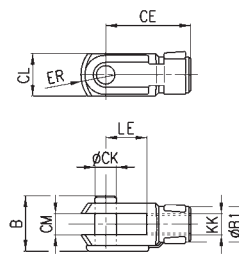
 ISO 8140
 Materiale: Acciaio zincato

Mod.	øCK	LE	CM	CL	ER	CE	KK	B	B1
G-25-32	10	20	10	20	12	40	M10 X 1,25	26	18
G-40	12	24	12	24	14	48	M12 X 1,25	32	20
G-50-63	16	32	16	32	19	64	M16 X 1,5	40	26
G-80-100	20	40	20	40	25	80	M20 X 1,5	48	34
G-41-125	30	54	30	55	38	110	M27 X 2	74	48

Dado stelo Mod. U

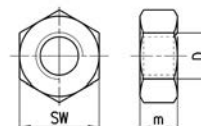
 UNI EN ISO 4035
 Materiale: Acciaio zincato

Mod.	D	m	SW
U-25-32	M10X1,25	6	17
U-40	M12X1,25	7	19
U-50-63	M16X1,5	8	24
U-80-100	M20x1,5	9	30
U-41-125	M27x2	12	41

Snodo autoallineante Mod. GK

Materiale: Acciaio zincato

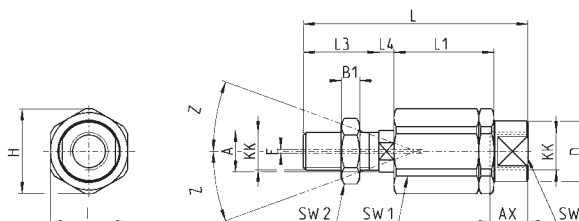

INGOMBRI																	
Mod.	Ø	KK	L	L1	L3	L4	øA	øD	H	I	SW	SW1	SW2	B1	AX	Z	E
GK-25-32	25-32	M10x1,25	71,5	35	20	7,5	14	22	32	30	19	12	17	5	22	4	2
GK-40	40	M12x1,25	75,5	35	24	7,5	14	22	32	30	19	12	19	6	22	4	2
GK-50-63	50-63	M16x1,5	104	53	32	10	22	32	45	41	27	20	24	8	30	3	2
GK-80-100	80-100	M20x1,5	119	53	40	10	22	32	45	41	27	20	30	10	37	3	2
GK-125	125	M27x2	147	60	54	10	32	57	70	65	54	24	41	12	48	4	2

Giunto compensatore Mod. GKF

Materiale: Acciaio zincato

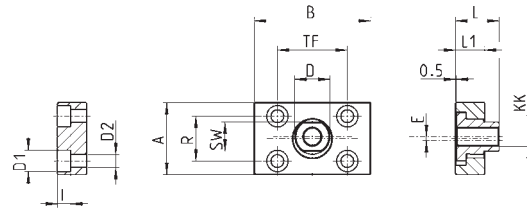

INGOMBRI

Mod.	Ø	KK	A	B	R	TF	L	L1	I	Ø D	Ø D1	Ø D2	SW	E
GKF-25-32	32	M10x1,25	37	60	23	36	22,5	15	6,8	18	11	6,6	15	2
GKF-40	40	M12x1,25	56	60	38	42	22,5	15	9	20	15	9	15	2,5
GKF-50-63	50-63	M16x1,5	80	80	58	58	26,5	15	10,5	25	18	11	22	2,5
GKF-80-100	80-100	M20x1,5	90	90	65	65	32,5	20	13	30,5	20	14	27	2,5
GKF-125	125	M27x2	90	90	65	65	35,5	20	13	40	20	14	36	4

Chiave speciale per smontaggio cilindri Ø 80-100 a tubo tondo

Materiale: acciaio temprato

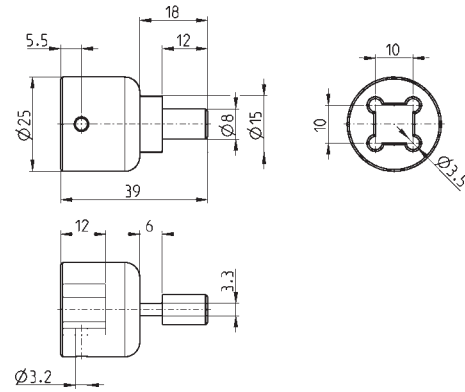

Mod.

80-62/8C