

Atlas Copco

Oil-free air for dental and medical applications



Premium Surgical Air

Atlas Copco



Total capability, total responsibility

Right at the heart of your business, Atlas Copco delivers quality compressed air for superior operational capacity. From compressed air generation to point of use, you can choose from our wide range of products to create a complete compressed air system tailored to your specific needs. All Atlas Copco products are engineered to integrate seamlessly, ensuring the highest level of reliability and energy efficiency. As a result, Atlas Copco can take full responsibility for your compressed air infrastructure with a guarantee of best-in-class quality. With a global presence in over 150 countries, we can provide an unrivalled service to maintain and continually improve your compressed air system performance.

Backed by 100 years at the forefront of compressed air, Atlas Copco products offer the finest quality and efficiency. Our goal is to be First in Mind—First in Choice®. That is why Atlas Copco's pursuit of innovation never ceases, driven by the dedication to meet and exceed your demands. Always working with you, we are committed to providing the customized air solution that is the driving force behind your business.

Atlas Copco:
***Customized Quality Air Solutions through
Innovation, Interaction and Commitment.***

Clean and quiet air for point-of-use installations

Whether you work in a small dental practice, a veterinary lab, a hospital clinic or a clinical work environment, maximum hygiene is your main priority. To successfully perform clinical work and make sure your equipment functions effectively, you rely on ultra-clean air. Set to meet your specific demands and suit a variety of applications, Atlas Copco offers a full range of state-of-the-art compressor solutions to produce pure surgical air.



100% CLEAN AIR

Compressed air: your surgical practice depends on it to safeguard your patient's health and protect your valuable equipment. Similarly, laboratory processes require high-quality air. To provide an environment that is non-conductive to bacterial growth and contamination, you need absolutely pure and dry air. By opting for Atlas Copco's SF and LFX MED oil-free compressor solutions with integrated membrane dryer, you obtain 100% oil-free, ultra-dry and filtered air. The ideal tool to create a perfectly hygienic and aseptic environment and guarantee the long term operation of any surgical and laboratory equipment.



SOLID RELIABILITY

To keep you up and running at all times and guarantee your peace of mind, a dependable flow of pure air is crucial. Continuous market anticipation, years of experience and technological innovation have made Atlas Copco what it is today: a leading global manufacturer of compressor solutions. Our newly designed oil-free point-of-use solutions once more give proof of that, providing clean and dry air, delivered in a quiet and compact package. Through durable engineering and tests, the LFX MED guarantees the generation of 50% more air as well as a 50% longer lifetime compared to similar products on the market.



POINT-OF-USE

Designed with your specific work area in mind, Atlas Copco's LFX MED and SF solutions fit into any space or setting thanks to their:

- limited noise operation and compact design
- totally integrated, pre-assembled set up minimizing installation time and costs
- full front access for easy maintenance and improved user-friendliness



The complete quality air package

Generating guaranteed 100% oil-free, ultra-dry air, Atlas Copco's LFX MED and SF range protects valuable surgical and laboratory equipment from premature failure due to the effects of moist air and the build-up of oil residue.

LFX MED OIL-FREE PISTON COMPRESSORS

STANDARD FEATURES

- 1 AIR INLET FILTER**
 - reduced noise
 - improved air quality: 1 micron filtration
- 2 OIL-FREE POWER BLOCK WITH PATENTED SUPERFLOW**
 - high performance
 - extended lifetime
- 3 AFTERCOOLER**
 - first drying of the air through cooling
 - extended lifetime of the membrane dryer
- 4 WHITE CANOPY**
 - reduced noise
- 5 24/50 LITER WHITE AIR RECEIVER**
 - no corrosion and risk of contamination thanks to clean and dry air stored in an internally coated, fully approved receiver
 - space-saving due to small footprint and reduced overall height
- 6 SUCTION CUPS**
 - improved vibration damping

EXTRA FEATURES (FULL FEATURE VERSION)

- 7 PULSATION DAMPER**
 - unique guaranteed lifetime of the membrane dryer
- 8 DD FILTER AND PD FILTER**
 - DD: water separation and first 1-micron filtration
 - PD: ultra-clean air through 0.01 micron filtration
 - DD+PD: extended lifetime of the membrane dryer
- 9 P OR N SERIES SD MEMBRANE DRYER**
 - state-of-the-art dryer technology
 - different dryness (pressure dew point) for application specific quality air requirements
 - no maintenance/no disposal of waste desiccant
 - lowest noise level
 - limited air purge thanks to optimized nozzle sizes

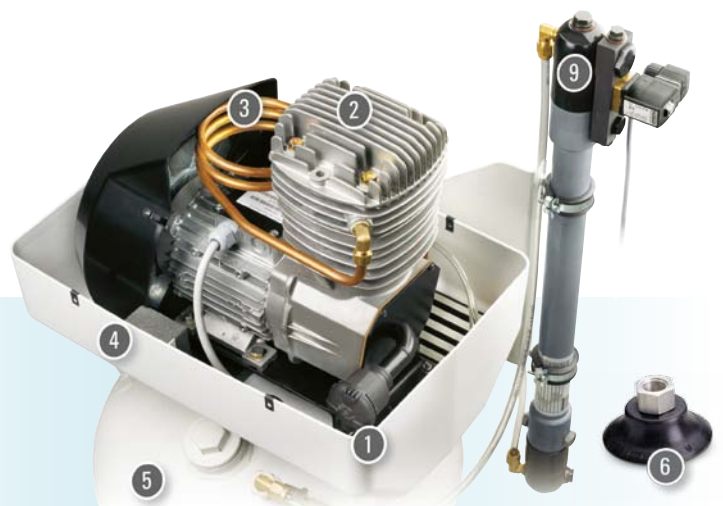
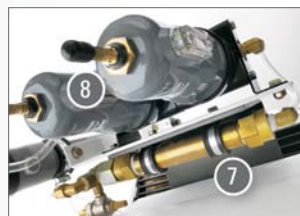

Fundamental to the design of these compressor models are their high-quality standard components: essential for superb performance and efficient, trouble-free operation. Supplied as quality air point-of-use packages, the LFx MED and SF are set to power up your practice!

SF OIL-FREE SCROLL COMPRESSORS

STANDARD FEATURES

- 1 AIR INLET FILTER**
 - highly efficient elimination of dust and particles down to 1 micron
- 2 MOTOR**
 - totally enclosed air cooled IP55 class F motor
- 3 COMPRESSOR ELEMENT**
 - air cooled
 - slow speed element ensuring extremely low noise level
 - limited number of moving parts guaranteeing long operating life with limited number of service interventions
- 4 COMPRESSED AIR AFTERCOOLER**
 - first drying of the air through cooling
 - extended lifetime of the dryer
- 5 CANOPY**
 - reduced noise
- 6 BELT TENSION**
 - simple drive belt tension system eliminating the need for a gearbox

EXTRA OPTIONAL FEATURES

AIR RECEIVER

- corrosion prevention thanks to fully approved internally coated 2 x 16 liter integrated receivers or 270 liter receiver

INTEGRATED REFRIGERANT DRYER

(FULL FEATURE VERSION) OR OPTIONAL DESICCANT DRYER

- different dryness (pressure dew point) for application specific quality air requirements

FILTERS

- pre-filter and built-in after-filter on units with CD dryer

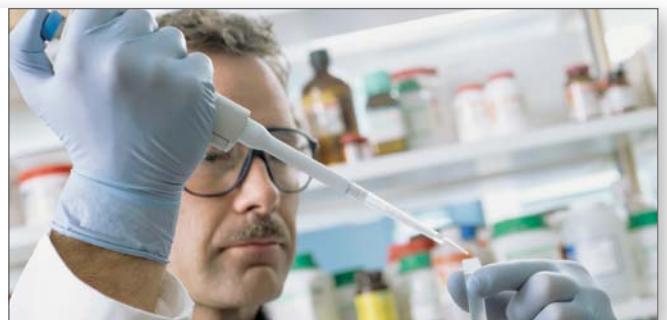
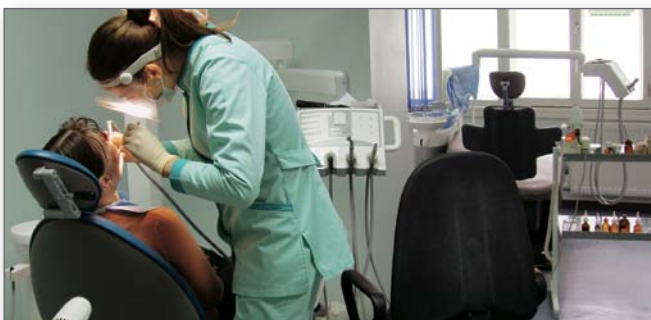

First-class oil-free air

The combination of 100% oil-free operation and removal of particulate contaminants and moisture provides you with a complete air package. Generating the exact standard of clean air you require, the LFx MED and SF series are synonym for the leading edge technology your practice or lab depends on.

TOP QUALITY

To protect the patient from infection and safeguard your equipment, you need air of the very highest standard. Nowadays, national and international organizations issue specific norms for surgical air in dental practices, clinics and hospitals. Both the UK

Health Technical Memorandum 2022 (HTM 2022) and ISO 7396-1 ensure air is supplied to the highest standards of quality control. Our LFx MED or SF series easily meet and exceed the requirements for both norms, allowing you to rest assured at all times.

	Pressure dew point requirements	Atlas Copco solution
ISO 7396-1 SECTION ON SURGICAL AIR	<5°C and >= 5°C lower than minimum use temperature	LFx MED FF-P SF FF
HTM 2022 SUPPLEMENT 1 ON DENTAL AIR	-20°C	LFx MED FF-N SF + CD dryer

AT THE HEART OF YOUR WORK AREA

Designed for the specific needs of dental practices, clinical laboratories and other medical point-of-use surgical air applications, the LFx MED and SF range of compressor solutions

offer unmatched performance, durability and lifetime with minimal maintenance. In short: a sensible investment for the highest quality surgical air installations.



- quiet, low vibration, simple to use
- perfectly hygienic and aseptic environment
- maximum reliability and guaranteed long term operation of dental equipment



- extremely low noise levels and low vibration
- complete integration for maximum compactness
- easy installation at point-of-use

	LFx MED	SF
PRESSURE REDUCER	•	
ELECTRONIC TIMER DRAIN	•	•
EWD ZERO LOSS DRAIN		•
INTEGRATED REFRIGERANT DRYER		•
CD ADSORPTION DRYER		•
90 LITER WHITE AIR RECEIVER	•	
INTEGRATED 2X16 LITER AIR RECEIVER		•
270 LITER AIR RECEIVER		•
WHEEL SET (ON 50/90 LITER RECEIVER)	•	

Technical data

COMPRESSOR TYPE	Maximum working pressure		Capacity FAD* 1500 rpm (50 Hz)			Capacity FAD* 1800 rpm (60 Hz)			Motor power		Noise level**	Weight	Air receiver size
	bar(e)	psig	l/s	m ³ /min	cfm	l/s	m ³ /min	cfm	kW	hp	dB(A)	kg/lb	l/gal.
LFx 0.7 MED	8	116	1.02	0.06	2.16	1.35	0.08	2.86	0.55	0.75	61	47/104	24/6
LFx 1.0 MED	8	116	1.38	0.08	2.92	1.46	0.09	3.09	0.75	1	61	61/134	24/6
LFx 1.5 MED	8	116	2.07	0.12	4.39	2.39	0.14	5.06	1.2	1.5	62	65/143	50/13
LFx 2.0 MED	8	116	2.53	0.15	5.36	NA	NA	NA	1.5	2	64	65/143	50/13
SF1	8	116	2.7	0.16	5.7	2.7	0.19	6.57	1.5	2	53	104/229	2x16/8.5 or 270/80
SF2	8	116	4	0.24	8.5	4	0.29	8.69	2.2	3	55	123/271	2x16/8.5 or 270/80
SF4	8	116	6.7	0.4	14	6.7	0.4	14	3.7	5	57	132/291	2x16/8.5 or 270/80

* Unit performance measured according to ISO 1217, Ed.3, Annex C-1996.

** Mean noise level measured according to ISO 2151/Pneurop/Cagi PN8NTC2 test code; tolerance 2 dB(A).

Reference conditions:

- Absolute inlet pressure 1 bar (14.5 psi)
- Intake air temperature 20°C, 68°F

FAD is measured at 7 bar.

Recommended number of chairs (at 50 Hz)	No dryer	ISO 7396-1 – Section on surgical air	HTM 2022 – Supplement 1
1	LFx 0.7	LFx 0.7 FF-P	LFx 0.7 FF-N
2	LFx 1.0	LFx 1.0 FF-P	LFx 1.0 FF-N
3	LFx 1.5	LFx 1.5 FF-P	LFx 1.5 FF-N
4	LFx 2.0 / SF1	LFx 2.0 FF-P / SF1 FF	LFx 2.0 FF-N / SF1 + CD
6	SF2	SF2 FF	SF2 + CD
10			SF4 + CD
12	SF4	SF4 FF	

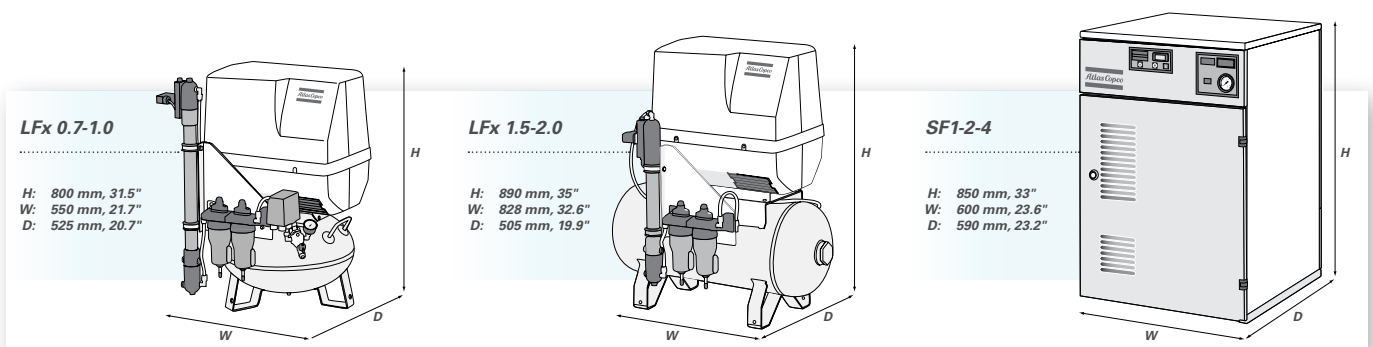



In order to be First in Mind—First in Choice® for all your compressed air needs, Atlas Copco delivers the products and services that help increase your business' efficiency and profitability.

Atlas Copco's pursuit of innovation never ceases, driven by your need for reliability and efficiency. Always working with you, we are committed to providing you the customized quality air solution that is the driving force behind your business.



Never use compressed air as breathing air without prior purification in accordance with local legislation and standards.